

# DOME0 E

Bed for standard nursing care

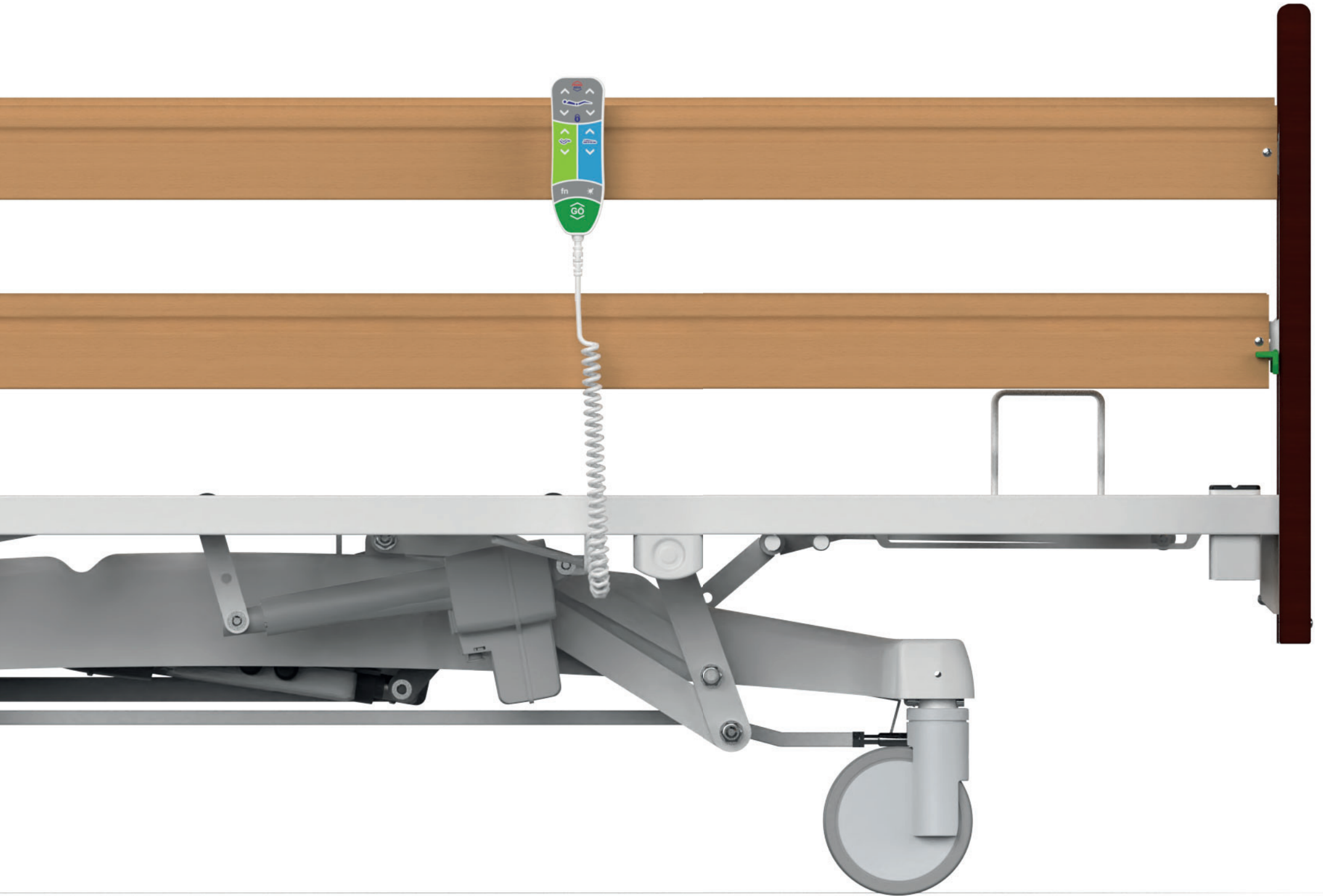

# DOMEO E

Bed for standard nursing care.

DOMEO E electric care beds are specially designed for standard nursing care, especially for people with reduced mobility or those who need assistance with everyday activities. These beds are equipped with various features such as electric positioning, robust folding side rails and a controller with colour-coded functions that make the nurses job easier and help the clients to be independent.

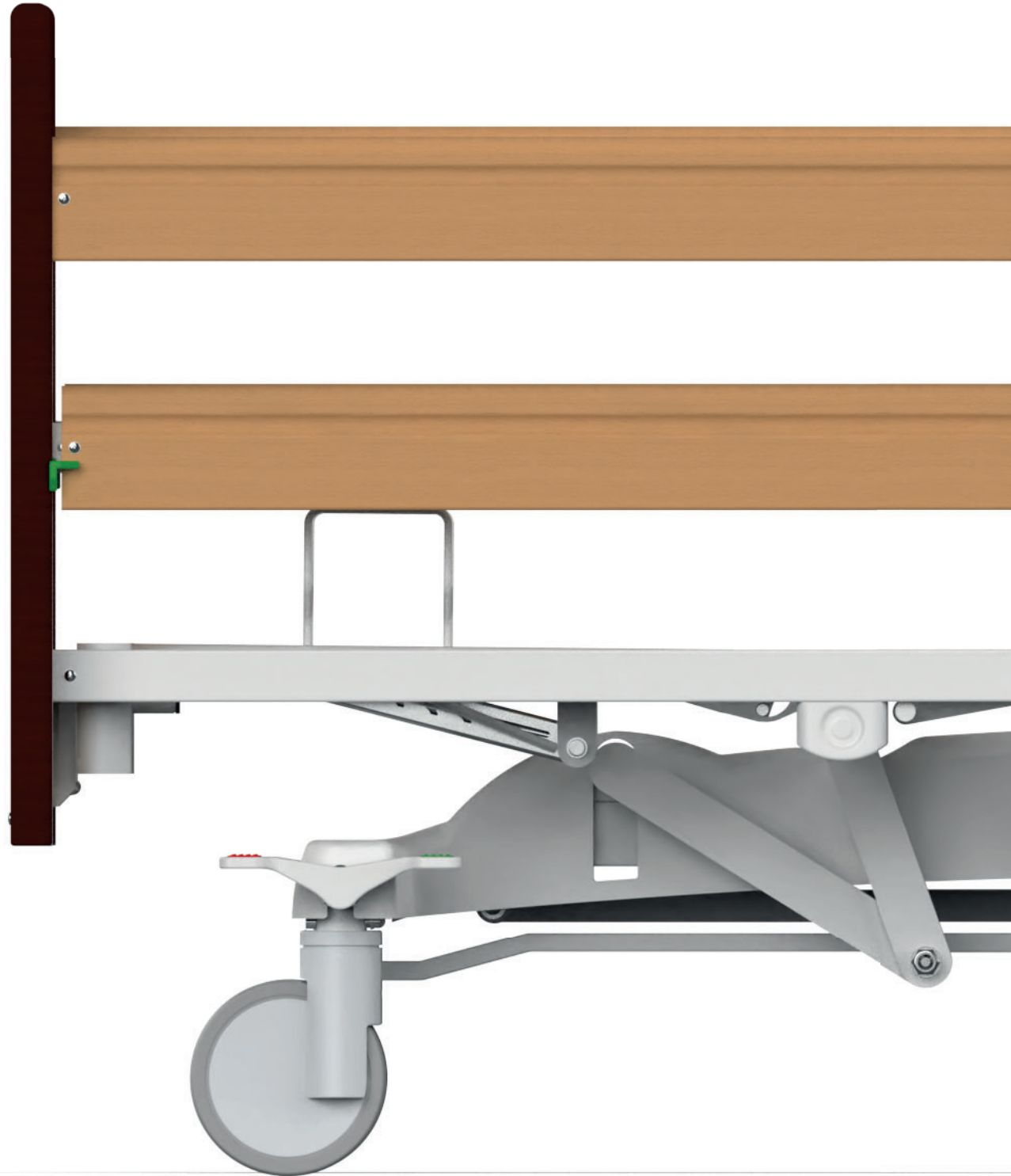



## Increased load capacity

The solid and stable construction with a safe operating load of up to 250 kg provides safe support even when caring for patients with higher weight. Thanks to the materials and technologies used, extremely high durability is ensured even under repeated increased loads.

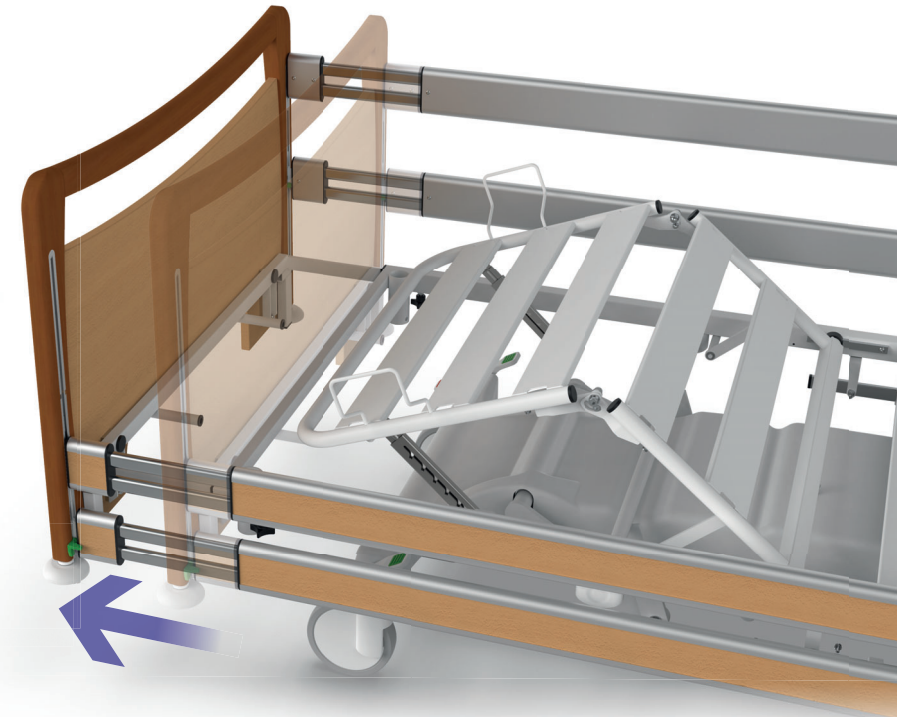

## Extension of the mattress platform

Extending the mattress platform increases comfort even for taller patients and makes it easier for staff to handle the patient.

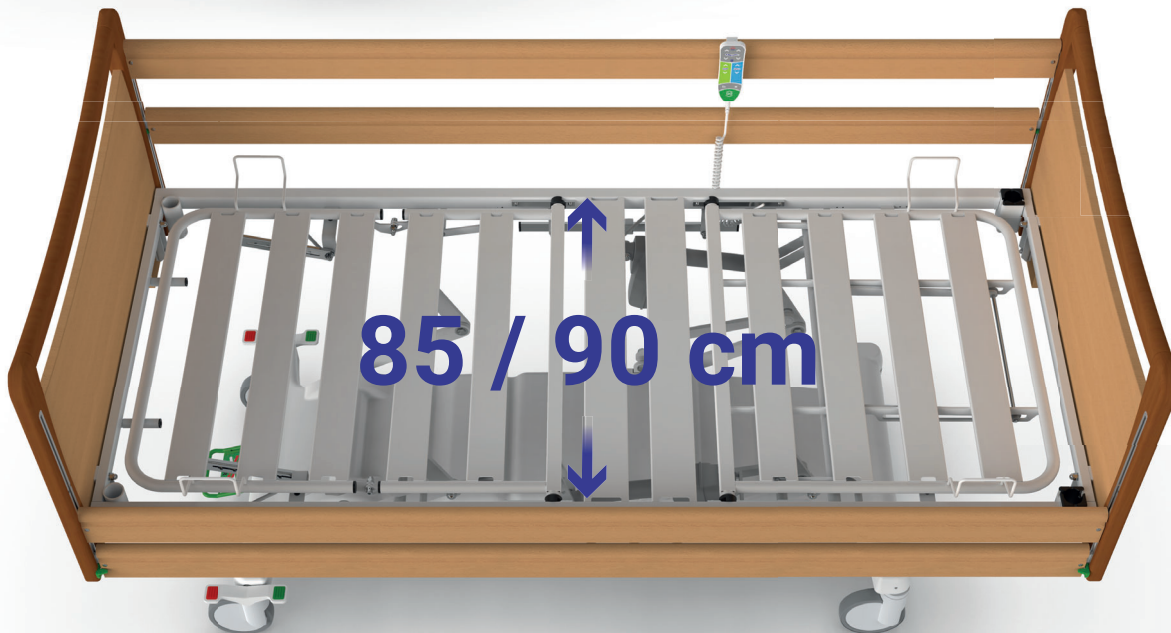

## Width of the mattress platform

The optimal width of the mattress platform ensures maximum comfort for the patient and easy handling of the bed.

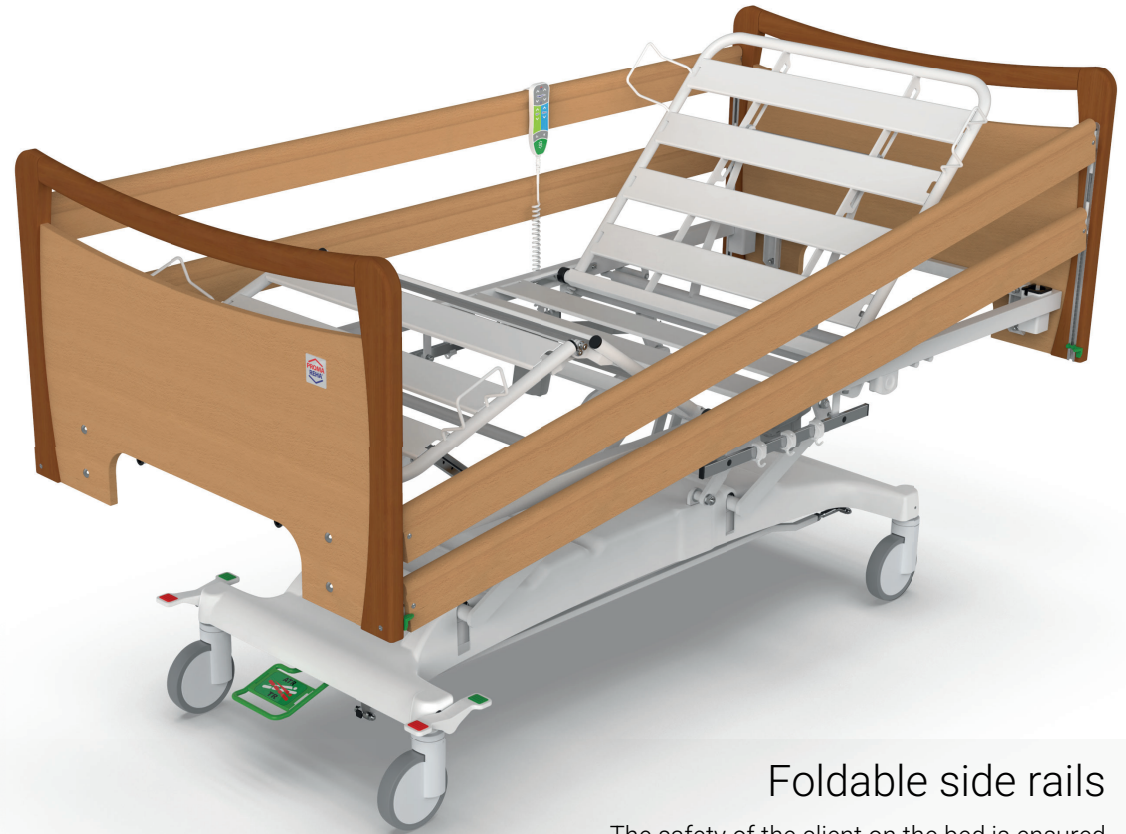
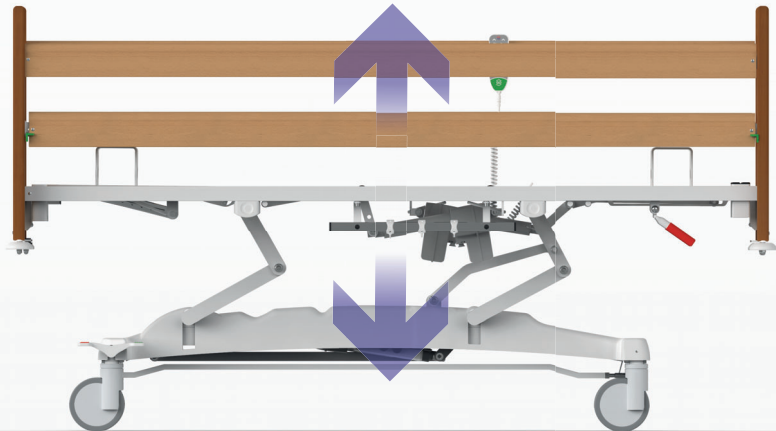
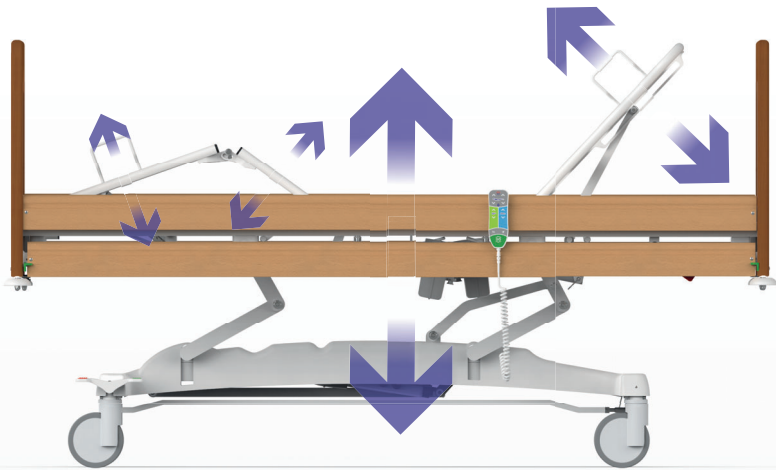

## Foldable side rails

The safety of the client on the bed is ensured by folding side rails. The easy folding of the side rails with two independent movements significantly reduces the risk of accidental lowering. The folded side rails are positioned sufficiently below the mattress level to allow easy exit from the bed.

## Comfortable positioning

The increased range of the bed lift reduces the strain on staff and facilitates the client handling. The reduced minimum height of the mattress platform assists the client in exiting the bed. The electric positioning of the back and thigh section in combination with the mechanical positioning of the calf section allows a wide range of adjustment of the individual parts of the mattress platform. The staff and client can conveniently adjust the individual positions using the hand control.



Universal accessories holders

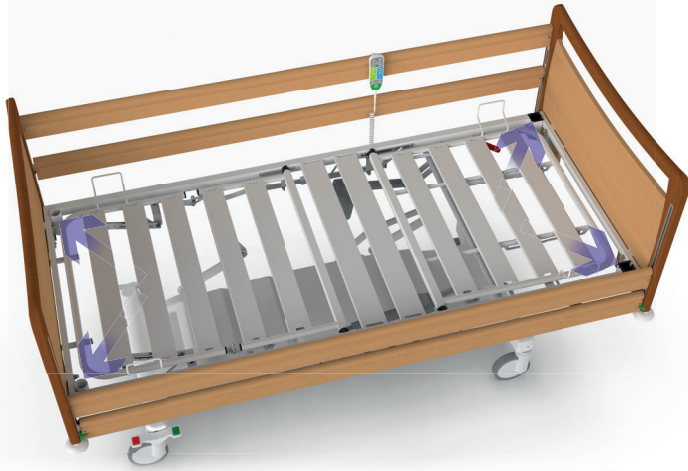

Bumper wheels

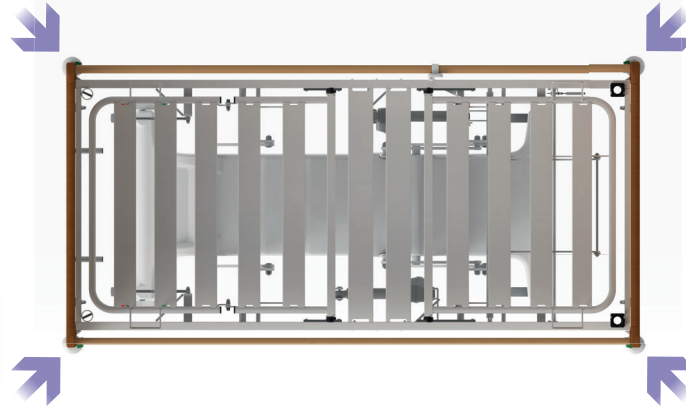

CPR

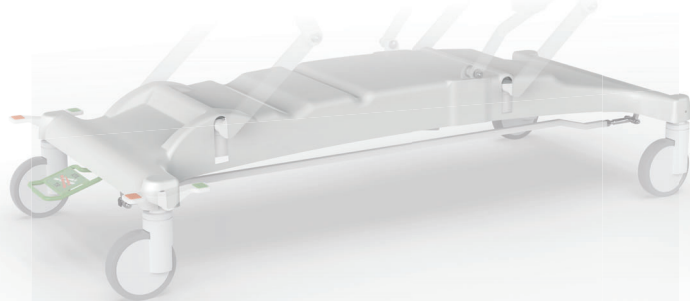
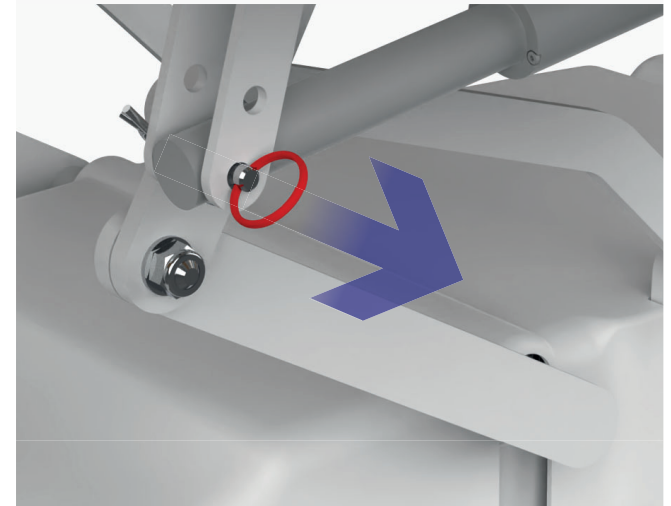

Plastic undercarriage cover

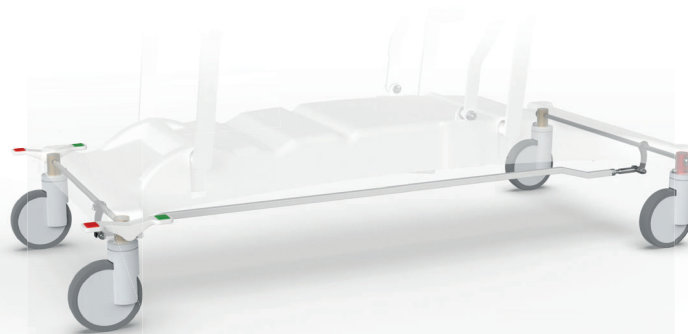

Plastic wheels with central brake

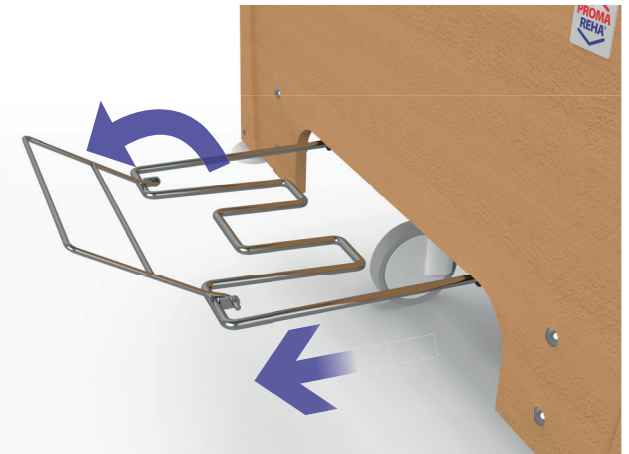

Bed linen shelf

## Mattress holders

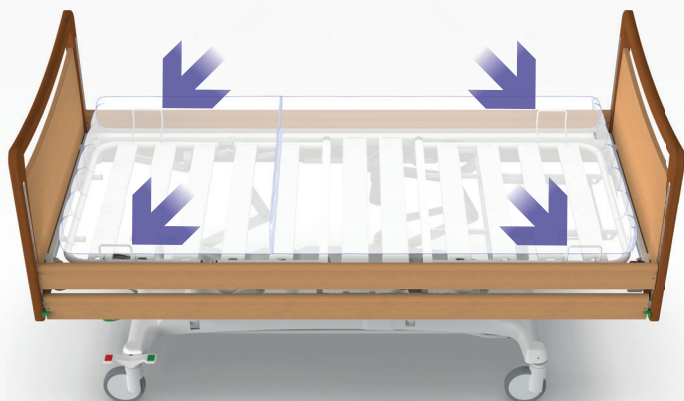

## Choice of design and decor

Being able to choose the design and colour decor of care beds allows you to create an esthetic and welcoming space that can help improve mood, comfort and reduce stress.

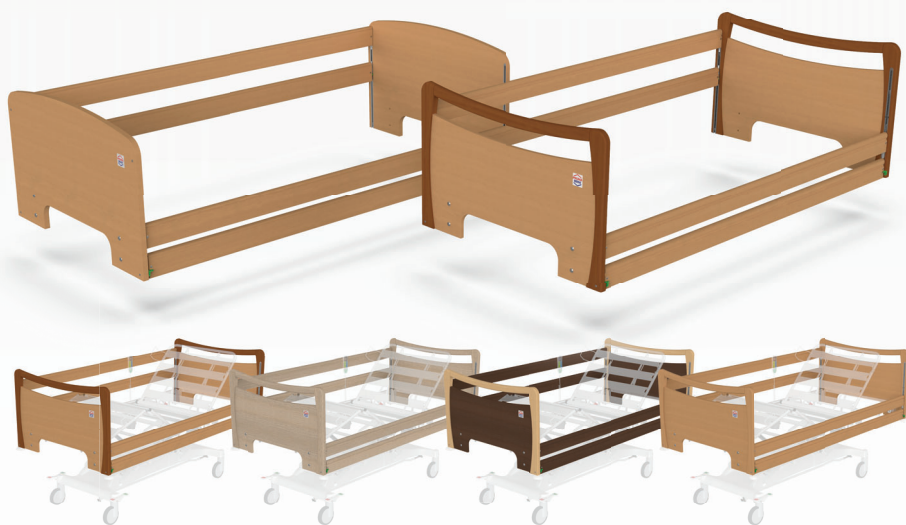

## Technical parameters

Mattress platform (length x width) .....	200 x 85 (90) cm
Outer bed dimensions (length x width) .....	206 (207) cm x 98 (103) cm
Mattress platform height .....	39,5 - 78,5 cm
Mattress platform extension .....	20 cm (optional)
Weight .....	118 kg
Safe working load .....	250 kg
Maximum patient weight .....	215 kg
CPR of the back .....	None
The bed is designed for application environments .....	3, 4
Bedding area .....	metal slats (plastic removable optionally)
Types of bedheads .....	UNI P, UNI K

## Bed equipment

Castors .....	Metal, plastic (optional)
Bumper wheels .....	Yes (optional)
Central brake .....	Yes (optional)
Universal accessory holder .....	Yes 2x (optional)
Plastic hooks for universal accessory holder .....	Yes 6x (optional)
Chassis cover .....	Yes (optional)
Accessory holders .....	Yes 4x
Bed linen shelf .....	Yes (optional)
Patient control .....	Yes
Backup battery .....	Yes (optional)

