

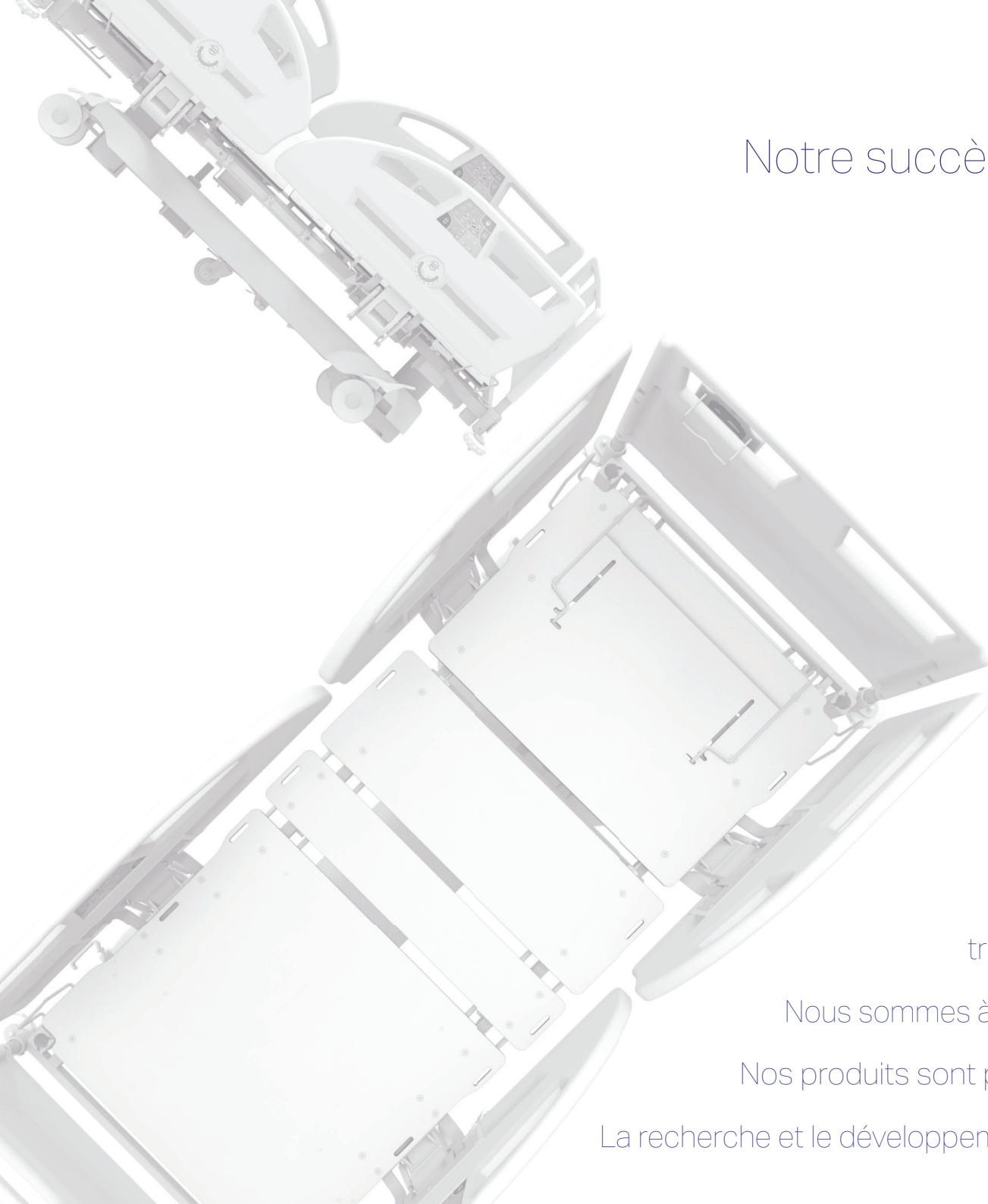

Catalogue des produits



Notre succès repose sur un travail acharné et honnête, des produits de qualité et un service professionnel.

Une entreprise forte d'une longue tradition, tradition de 35 ans en lien étroit avec le groupe VCL. Nous sommes à l'écoute des souhaits et des besoins de nos clients. Nos produits sont présents dans plus de 70 pays à travers le monde. La recherche et le développement en interne fournissent des solutions de pointe.

# Bienvenue chez Proma Reha



PROMA REHA est un fabricant traditionnel de lits médicaux et de soins qui s'est établi avec succès sur les marchés internationaux. L'entreprise occupe une position forte en Scandinavie, en Europe de l'Est, en Afrique du Nord et au Moyen-Orient. Ce succès repose sur un travail acharné, des produits de qualité et un service professionnel.

L'entreprise possède une expérience dans le développement, la conception et la construction de lits médicaux depuis 1990.

Nos lits ont aidé les patients et le personnel médical dans plus de 70 pays à travers le monde. Nos produits sont constamment améliorés afin de co-créeer les tendances de la médecine moder-

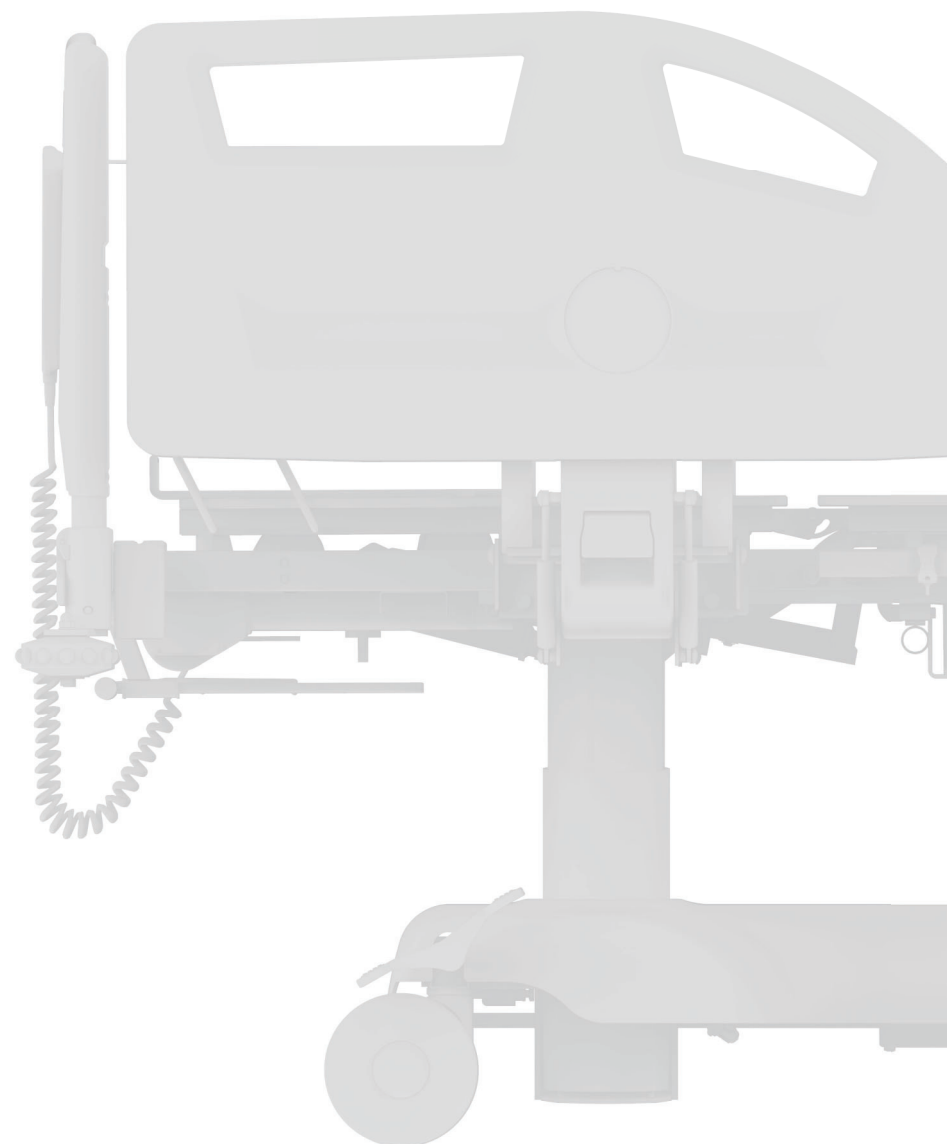

# TITAN PRO



Lit bariatrique avec système de pesage conçu pour les soins standards, supérieurs et intensifs .



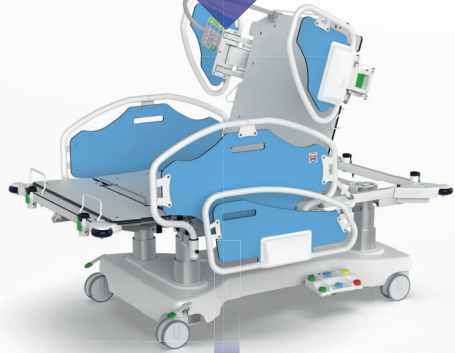
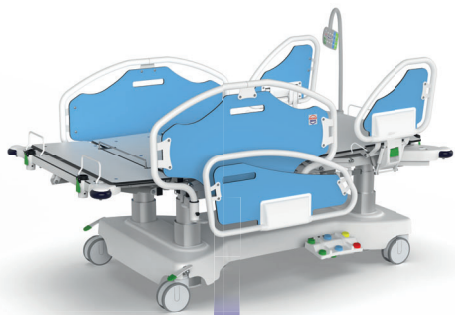

Posición de salida

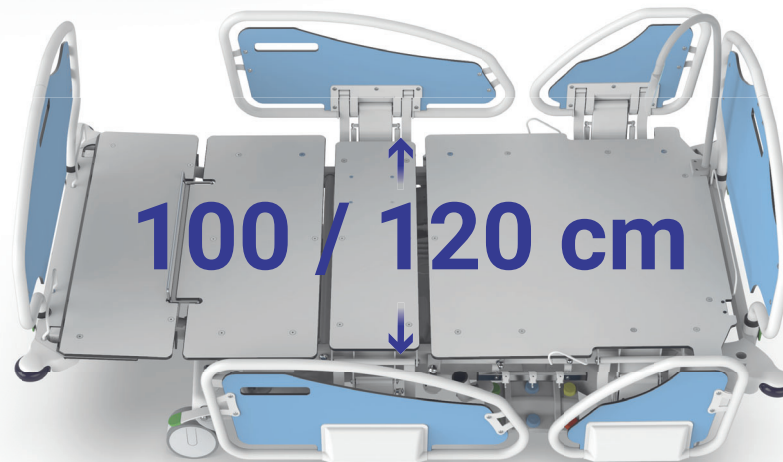
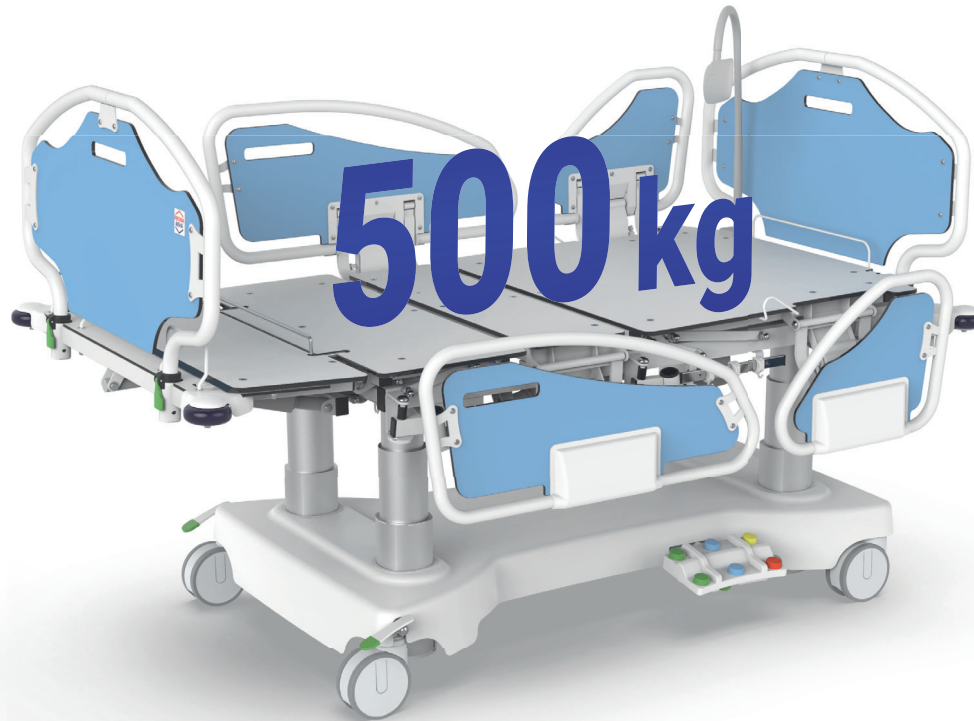

### Système de pesage

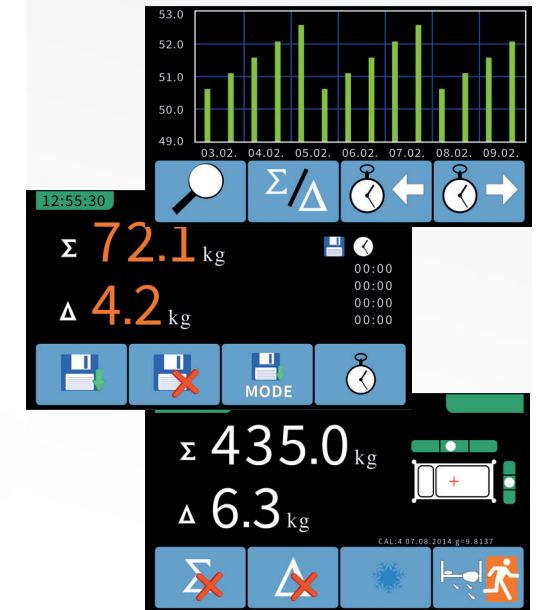

### Rayonable

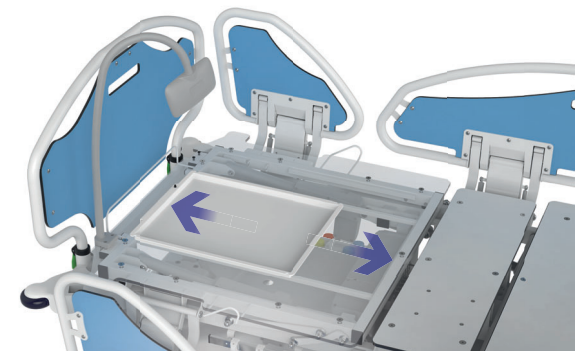

# VISTA, VISTA PRO

Le lit le plus avancé avec système de pesée pour les soins critiques et intensifs.



Marquage réfléchissant sur les extrémités du lit pour des déplacements plus sûrs autour du lit



### Système de pesage

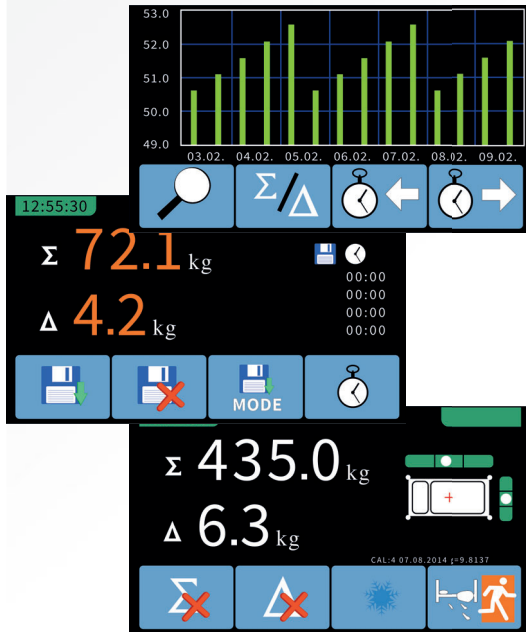

Augmentation de la charge de travail sûre



### Basculement bilatéral



Sellette - un meilleur contrôle

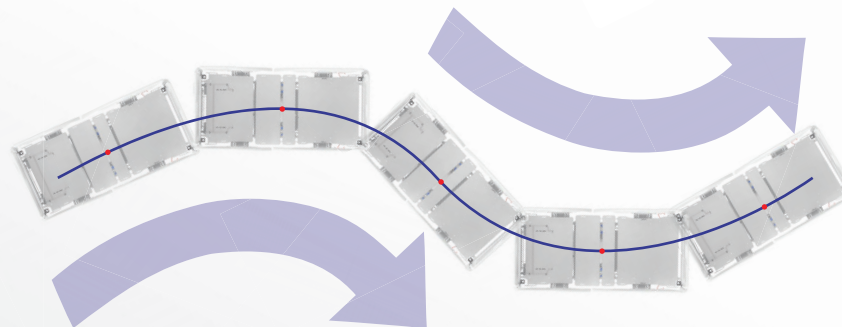

### Commandes avec fonctions codées en couleur



Système de retrait frontal simple



# INVENT, INVENT PRO

Lit avec système de pesée conçu pour les soins hospitaliers standards, supérieurs et intensifs



Marquage réfléchissant sur les extrémités du lit pour des déplacements plus sûrs autour du lit

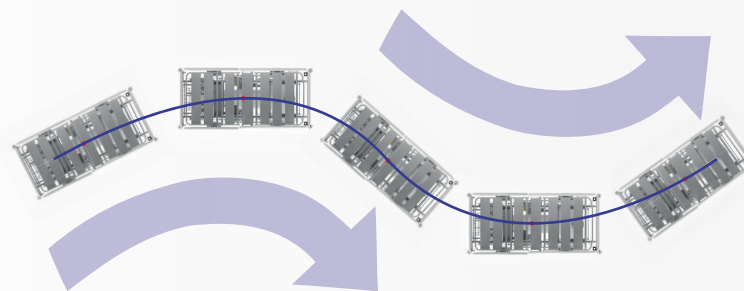
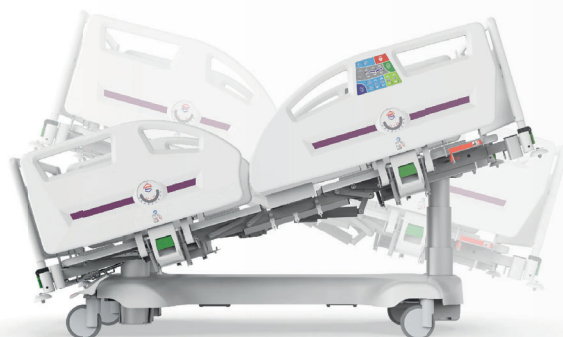

# GENEO



Le lit le plus populaire, non seulement pour les soins hospitaliers et ambulatoires, mais aussi pour les soins intensifs.



Marquage réfléchissant sur les extrémités du lit pour des déplacements plus sûrs autour du lit

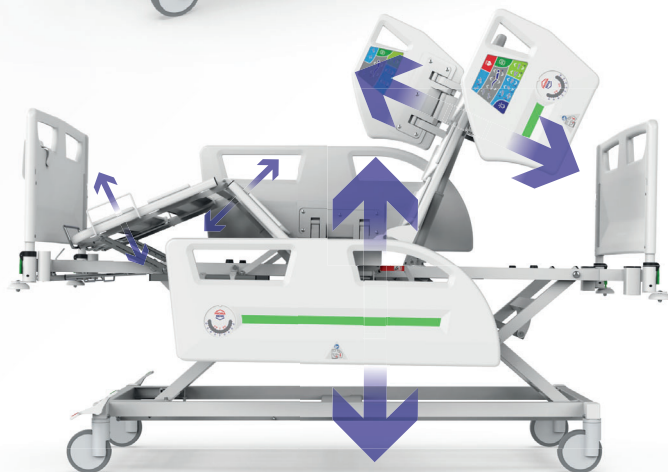

# Lits pour soins standard et extra-standard



SUPERTA H  
Positionnement hydraulique



SUPERTA E  
Positionnement électrique



Marquage réfléchissant  
sur les extrémités du lit pour  
des déplacements plus sûrs autour du lit

# Lit adapté aux patients agités



## SUPER TA H

Positionnement hydraulique



Une configuration de lit spéciale, conçue pour le confort et la sécurité des patients agités, crée un environnement qui soutient leur traitement et améliore leur bien-être pendant l'hospitalisation. Les lits sont équipés de modifications spéciales adaptées aux besoins de ces patients.

# Programme bariatrique

## TITAN

Lit bariatrique avec système de pesée conçu pour les soins hospitaliers standards, supra-standards et intensifs avec une capacité de charge allant jusqu'à 500 kg



## TAURUS

Fauteuil de transport conçu pour le transport rapide de patients bariatriques pesant jusqu'à 320 kg.

Matelas bariatriques spéciaux pour lits TITAN actifs / passifs



## BUDDY/TEDDY

pour les enfants



## BABY

Lit pour nouveau-né

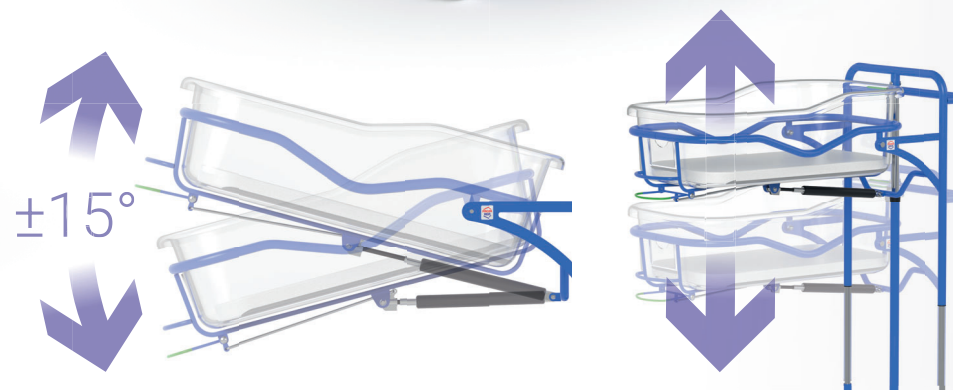

# Lits médicalisés

## GRANO

Positionnement électrique



## DOMEO H

Positionnement hydraulique

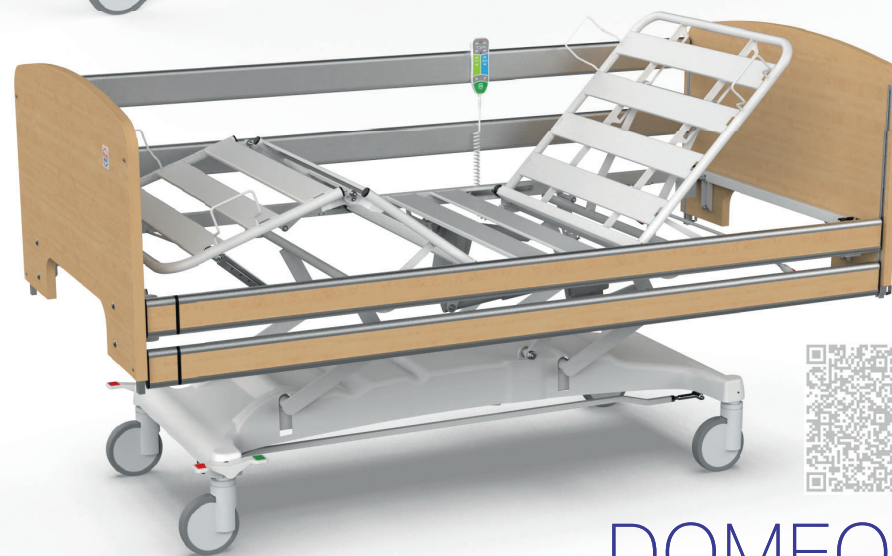

## DOMEO E

Positionnement électrique

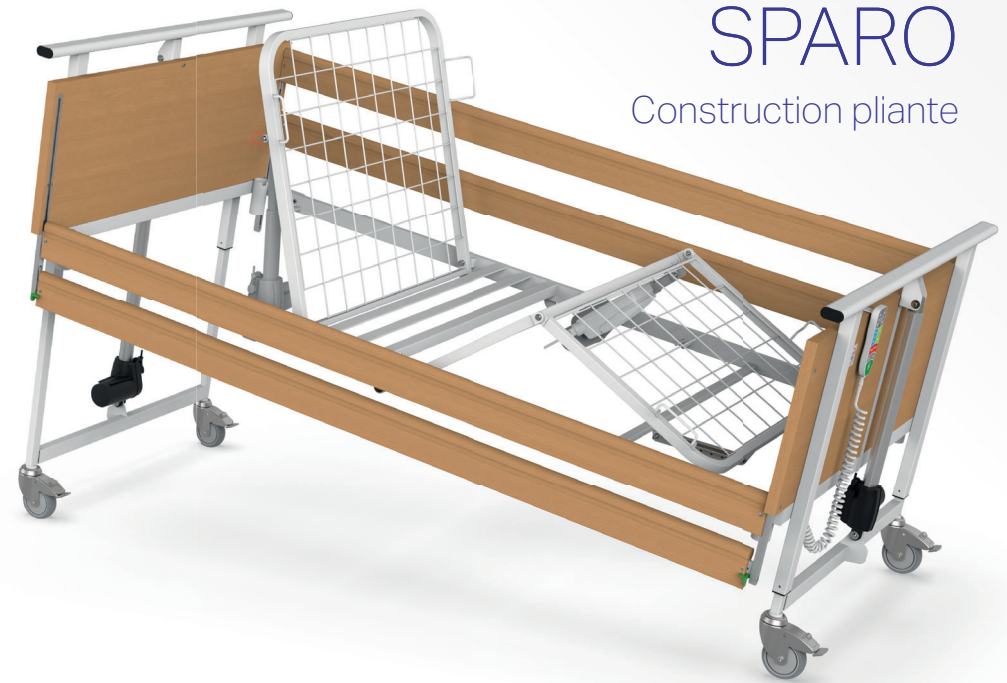

## Choix du décor

Hêtre

Chêne

Érable

Noyer

Sonoma

Nabucco

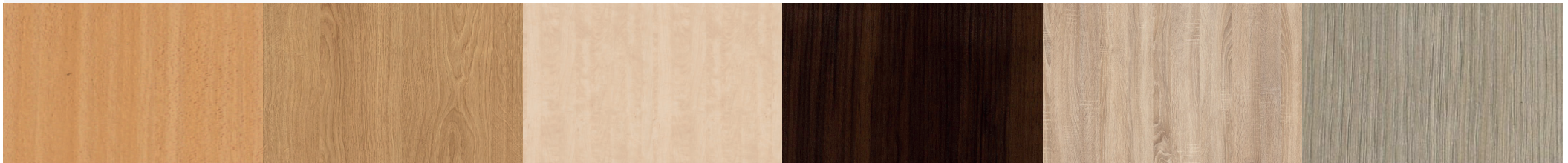

# Tables



NS-20



NS-21



NS-22





NS-2



NS-1



NS-3



# Table à manger



S-202-H



S-205-B



S-202-B

## Matelas passif anti-escarres

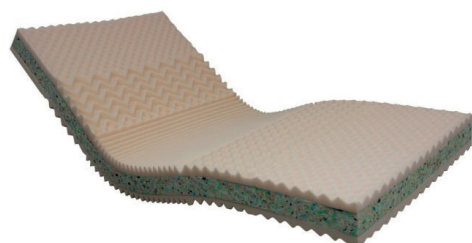
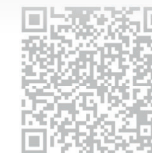

Sendvič



LUX P



LUX S



Soft Flex

## Matelas actifs et hybrides anti-escarres



Decu neo



Decu light

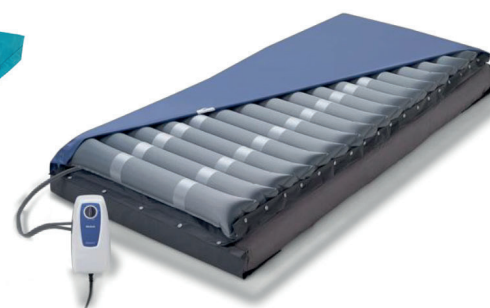

Domus 2 Plus



Domus Auto

# URGENT TOP

Fauteuil de transport pour un transport rapide et sûr des malades

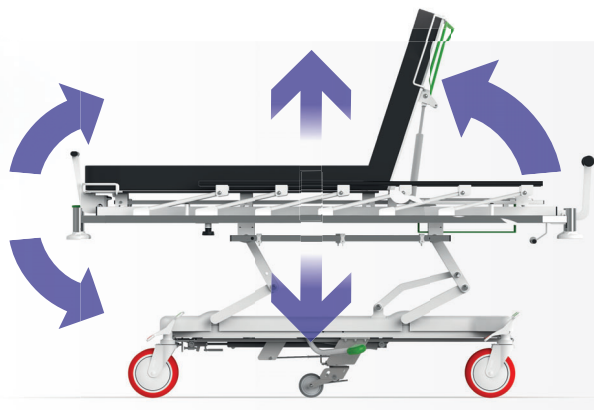
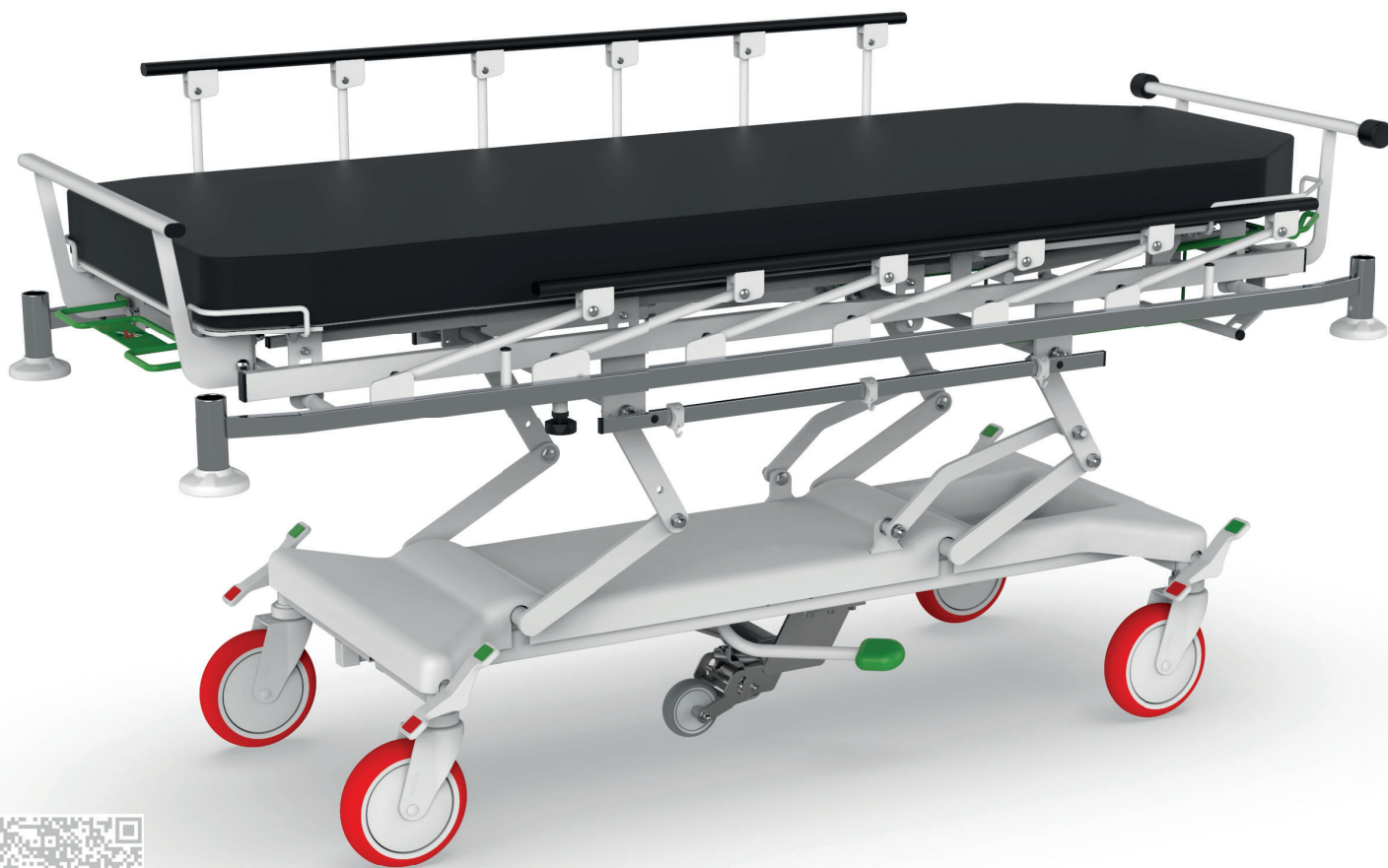



PRESTO  
Chariot de transport



CHARON  
Chariot de transport du défunt



# Réception et transport

## SHORTY

Apilable silla  
de transporte



## E-MO

Fauteuil de transport



## VERTICO

Lit de verticalisation



## RESTINO / RESTINO PLUS



# Fauteuil d'examen

## ELEVA E

Positionnement électrique



## ELEVA H

Positionnement hydraulique

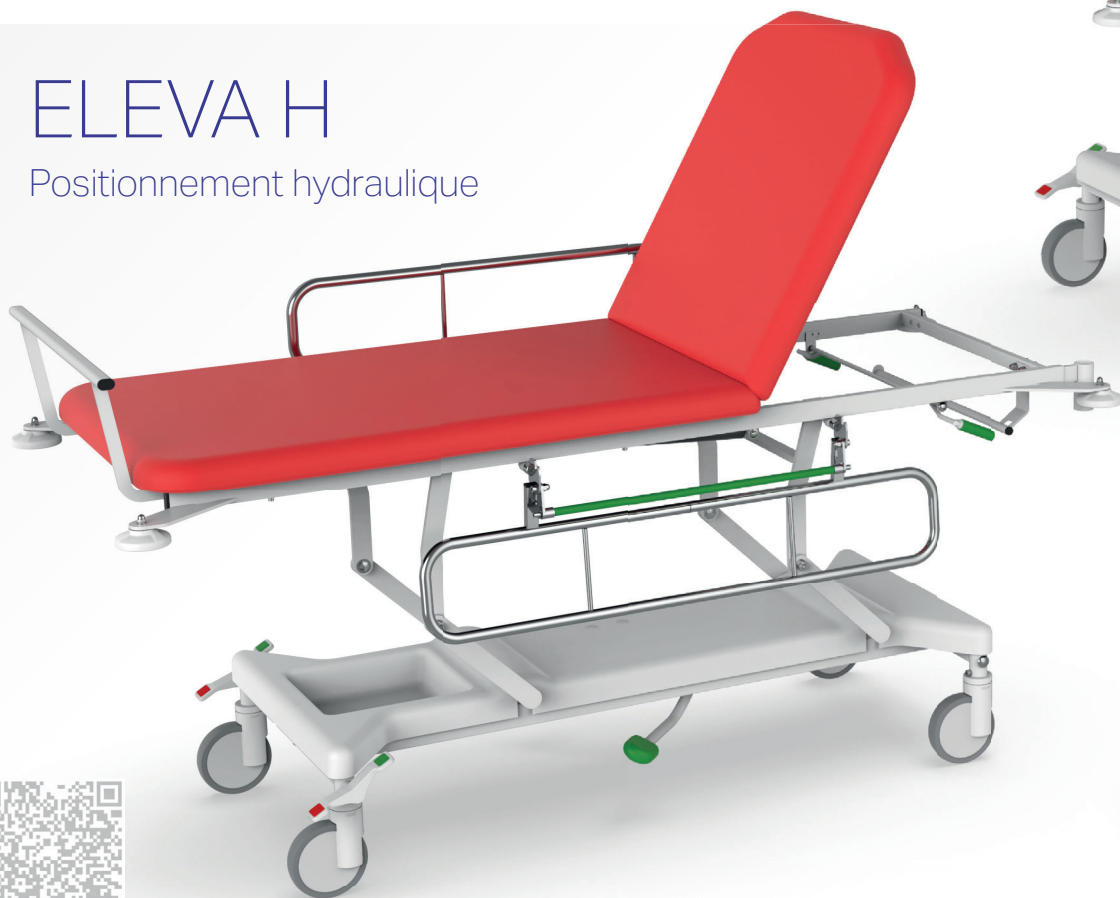

CLASSIC  
construction pliable

# Fauteuil de douche

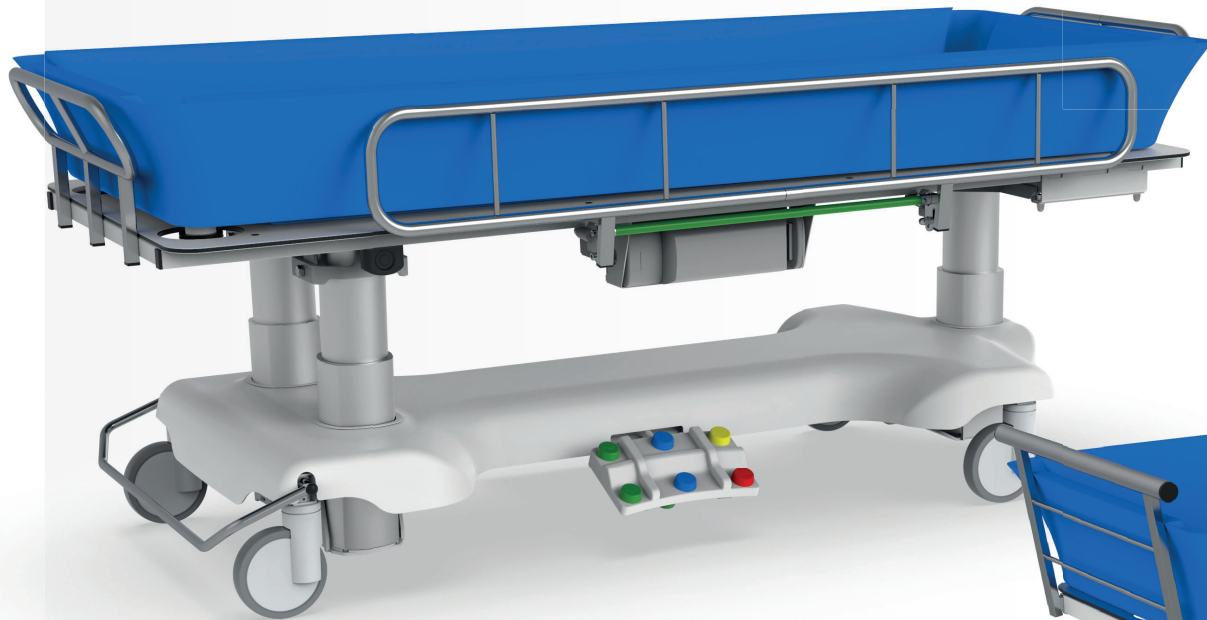

LUNA

Fauteuil de douche  
électrique à colonne



LAGUNA

Fauteuil de douche hydraulique



# Commentaire



A large rectangular area containing two columns of horizontal blue lines, intended for handwritten notes or comments.

# Commentaire



A large rectangular area containing two columns of horizontal blue lines, intended for writing a comment.



PROMA REHA, s.r.o.

Riegrova 342

552 03 Česká Skalice

Česká republika

+420 491 112 233

info@promareha.cz



[www.promareha.com](http://www.promareha.com)

© 06/2026

Les images sont à titre indicatif seulement.  
Sous réserve de modifications techniques.